

# 901

**SMALL  
AND EFFICIENT**



YOUR PARTNER  
IN PLASTIC JOINING

# Cutting edge technology and full equipment as a standard

## NO COMPROMISE FOR QUALITY

All components used by CEMAS are from world leading suppliers and never sub-brands.

Safety is our ultimate goal, as well as a prompt availability of spares worldwide.



## ERGONOMIC LOADING STATION

Special care was devoted to the manual loading steps of the process, both for small and large machines: to minimize effort on the backbone, the loading/unloading area was kept as close as possible to operator. There are no machines of the same class available on the market where this distance is so small.



## SAFE

Light curtains are fitted as a standard to ensure maximum operator safety, further to decreasing the total cycle time of each welding. Light curtains are integrated to protect them against collisions and as a result of an extremely accurate and well defined design.

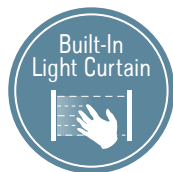

## WIDE REAR OPENING

Since the very beginning, all our vibration range was conceived to get tool change from the back of the machine, as maintenance door opening size always exceeds the width of the press bed.



## COMPACT BUT COMPLETE

CEMAS machines are the most compact machines available on the market, keeping engineering and vibration features unchanged, thus favoring ergonomics.



## HIGHLY CUSTOMIZABLE

Many standard features included in our machines are optional for competitors and, should this not be enough, just turn the page to discover a full range of over 60 optionals for your tailor-made machines.



## EASY MAINTENANCE

The use of the latest-generation electronic components has resulted in a remarkably smaller control panel, and in positioning the hydraulic unit below the control panel for the 240 Hz machines. This change has totally cleared an inner compartment and has made tooling maintenance and set up operations easier.



## CLEAN AND QUIET

Hydraulic power-plant outside the working area.





# INNOVATIVE OPERATOR INTERFACE SYSTEM

Accurate does not mean complicated: no other machine on the market is so "user friendly".

We have made a big effort in designing our video graphic to simplify any operation. Actually, there would be no need for operator's training.

- Switching to your language is as simple as pressing a key
- Parameters can be set to include up to 8 different welding steps
- Tool movement graphic programming: no need to call us for a new tool!
- Monitoring of the "just in time" process by displaying welding diagrams
- Constantly linked to CEMAS through the Teleservice system for diagnostics and customer's service on line



Graph screen



Tool programming



Production screen

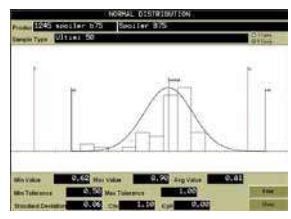

Statistical analysis

## 63 TOOL MEMORIES

The machine can store up to 63 different equipment parameters, of which 31 are automatically acknowledged. Data can be easily copied to other machines if needed.

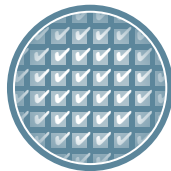

## ALWAYS AVAILABLE

Our standard machines are always available and can be rent to face even the most stringent production requirement in case of sudden demand increase.



## REALTIME TUNING

Our innovative generator is able to adjust the vibration frequency with no autotuning procedure. Internal values are checked and updated every 5ms to constantly ensure a perfect match of the equipment with the machine.

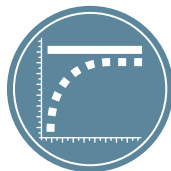

## ENERGY SAVING TECHNOLOGY

Big welding area and low power required: this is energetic efficiency!

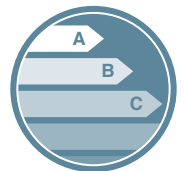

## QUICK VIBRATION STOP

This cutting edge feature can zero the vibration in less than 50 ms, for a more homogeneous and resistant joint.



**Top quality and cost-effectiveness**

**ST****HL****SC****IR****INPUT**

Power supply [50HzThree-phases+N+GND]	a.c. 400V	a.c. 400V	a.c. 400V	a.c. 400V
Pneumatic power (min.) [bar]	5	5	5	5
Maximum power required (peak load) [KW]	12	12	12	20

**OUTPUT**

Upper tool weight [Kg]	15÷35	20÷50	20÷50	20÷50
Generator power [KW]	16	16	16	16
Vibration frequency [Hz]	220÷240	220÷240	220÷240	220÷240
Vibration amplitude [mm]	0,4÷1,8	0,4÷1,8	0,4÷1,8	0,4÷1,8
PP equivalent welding area [cm <sup>2</sup> ]	300	400	300	300

**MECHANICAL DATA**

Vibration plate dimensions [mm]	880×520	880×520	880×520	880×520
Lifting table stroke [mm]	500	500	500	500
Lifting table maximum speed [mm/s]	250	250	500	500
Clamp net force (Gross) [KN]	15 net. (19)	15 net. (19)	18.8 net. (23)	17.5 net. (23)
Lifting table dimensions [mm]	1020×540	1020×540	1020×540	1020×720
Lifting table height [mm]	1000	1000	1000	1000
Front-door span [mm]	1050×750	1050×750	1050×750	1050×750
Upper door threshold [mm]	1755	1755	1755	1755
Lower tool weight [up to Kg]	-	-	-	-
Clearance between planes [mm]	200/700	200/700	200/700	200/700
Overall dimensions [W×D×H mm]	2230×1210×2170	2230×1210×2170	2230×1210×2170	2230×1810×2170
Total weight [Kg]	3100	3100	3100	4100
Hydraulic oil tank [Lt/ISO32]	55	55		

**CONTROL**

PLC Control	Siemens IM 151 - ET200	Siemens IM 151 - ET200	Siemens S7-CPU 1512SP	Siemens S7-CPU 1512SP
Operating panel	Siemens TP 1200	Siemens TP 1200	Siemens TP 1200	Siemens Pc Panel IPC 477D/477E
Vibration frequency tuning *	Continuous REALTIME	Continuous REALTIME	Continuous REALTIME	Continuous REALTIME
Welding steps [pressure, amplitude]	8	8	8	8
Welding depth sensitivity [mm]	0,01	0,01	0,01	0,01
Work settings memory	31 automatic equipment + 32 manual	31 automatic equipment + 32 manual	31 automatic equipment + 32 manual	31 automatic equipment + 32 manual
Type of communication	Profinet/Profibus	Profinet/Profibus	Profinet/Profibus	Profinet/Profibus

The digital generator ensures very short swing on/off vibration phases (50ms)

**REFERENCES**

Noise level ** [dB din 45635]	≤ 80	≤ 80	≤ 80	≤ 80
Work outcome definition	Automatic (good/reject)	Automatic (good/reject)	Automatic (good/reject)	Automatic (good/reject)
Work outcome printer	Custom Plus	Custom Plus	Custom Plus	Custom Plus
Holes on planes compatible with	Branson M-522H and M-5i2H	Branson M-522H and M-5i2H	Branson M-522H and M-5i2H	Branson M-522H and M-5i2H
Work pneumatic movements	2 (opt up to 10) valves + 1 (opt up to 2) vacuum circuits	4 (opt. up to 10) valves and 2 vacuum circuits	4 (opt. up to 10) valves and 2 vacuum circuits	4 (opt. up to 10) valves and 2 vacuum circuits
Remote-assistance	Optional	Included	Included	Included
Automatic rear door (for rear loading/unloading)	Optional	Optional	Optional	Optional

\* Thanks to our third-generation controller we have been able to eliminate the necessity of the auto-tuning cycle: the machine can adapt to the vibration frequency in real-time following the mechanical reactions of the vibrating system. Therefore, the outcome is a neater and more efficient vibration than the one obtained employing second-generation old systems.

\*\* Peak values can be higher for short periods depending on the application.

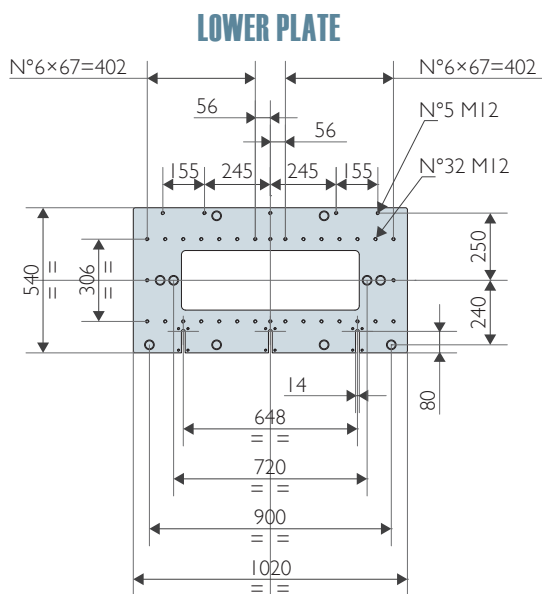
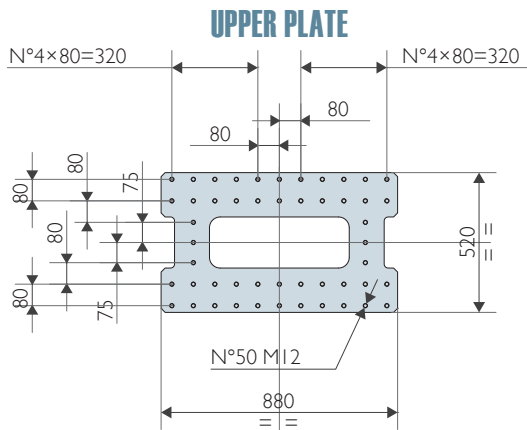
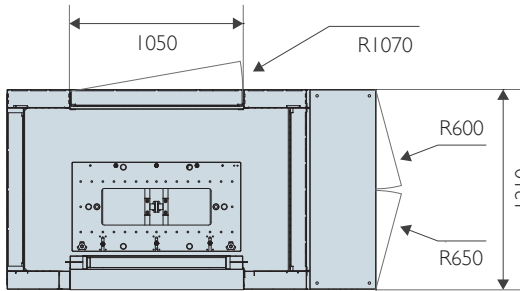
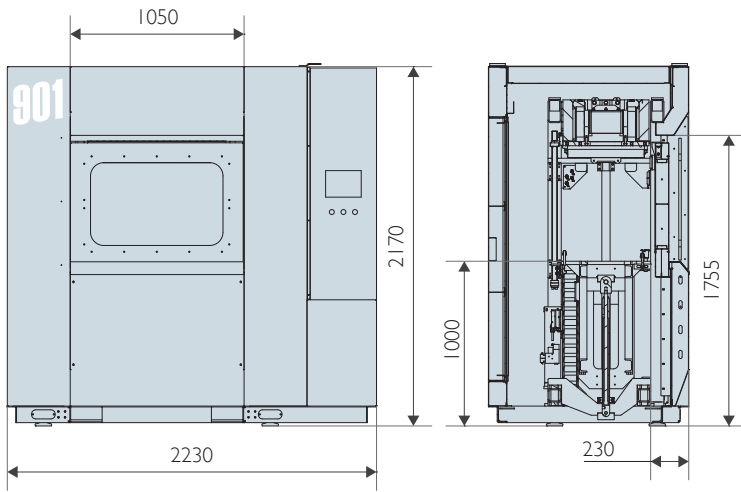

## ST STANDARD VERSION

The smallest of its range.

This machine is designed to weld tiny components by applying even a slight pressure, as well as more challenging parts.

Ideal for welding small-to-medium size taillights, intake manifolds, glove boxes, and spray-arms.

Available in 4 models, to include either an infra-red pre-heating or a hot plate type, it can be enriched with many optionals to ensure ultimate customizing.

As all the other CEMAS vibration machines, it is extremely compact in size when compared to the inner working area available.

## HL HI LEVEL

The HL version is different to the standard one as it includes some features making the machine even more flexible and powerful than ever. Just to mention some of the major changes, the welding power has been increased, more complex equipment and cycles can now be controlled, a teleservice module and a heavy duty vibrating plate have been included to make the machine suitable to frequent equipment changes.

## SC SERVO CONTROLLED

Have a look to the speed and thrust features: this machine is as fast and powerful as a rocket, for an unequalled production rate capability. Some of the HL features are also included. Further to the improved performances, the machine is clean and efficient from the point of view of power consumption and by far the best when compared to the traditional hydraulic machines.

As everybody knows, the IR pre-heating process is the solution to some major criticalities in the traditional vibration process. Listing the pros of this technology is simply pointless as you have probably opted for it because you know exactly what we are talking about.

Therefore, we would like to focus on how CEMAS has been dealing with it; this is not simply a matter of adjusting previous components to current needs but to devote our best effort to research & development until achieving a technology and an electronic system able to meet even the most stringent requirements.

Every detail has been accurately considered and designed for our machine, to include the IR sources, the control units, the power supply units and the interface software: all this is now part of our highly innovative modular system aimed at improving the IR heating system and to make it cost-effective, user's friendly and highly reliable.

Each 901 IR can be equipped with up to 16 Infrared Modules **IRM**, take a look here below.

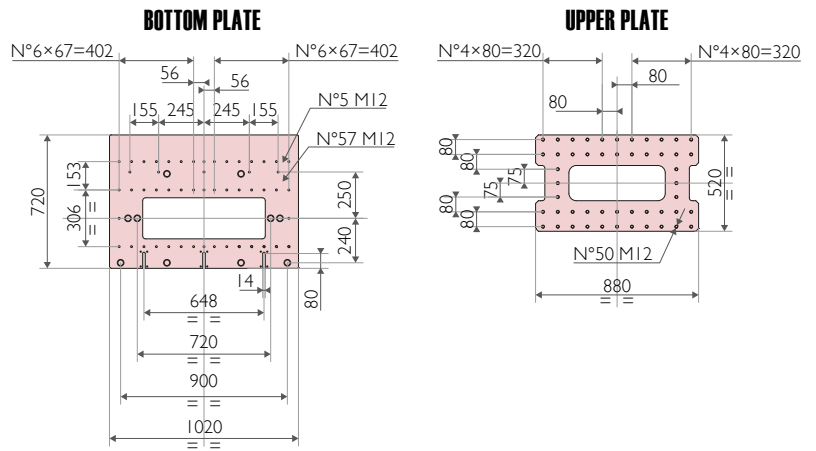
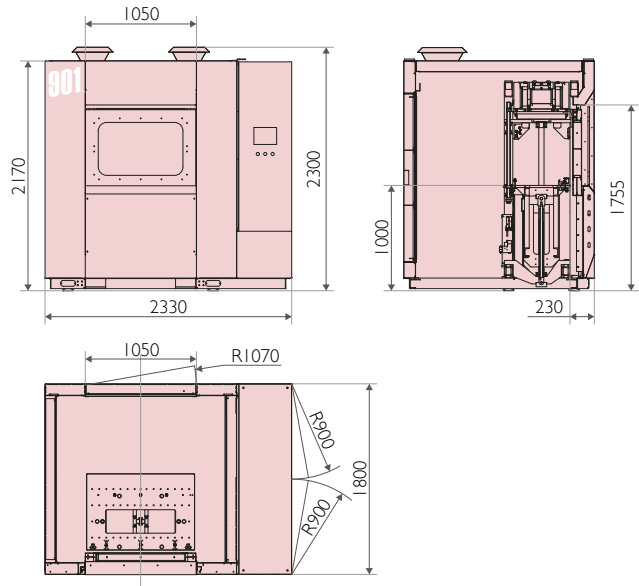

# Vibration Goes Hybrid!



Each medium wave emitter is operated by its own **IRM** controller



- ✓ Space saving solution
- ✓ Fully modular
- ✓ Smart design
- ✓ Easy maintenance

Proprietary technology that allows the **IRM** to retrofit existing third party machines via serial I/O sockets

The ultra fast protocol communication enables a FULLY DIGITAL MODULAR ARCHITECTURE

For unrivaled management, diagnostic and flexibility

Any application can be satisfied

The **IRM** control modules are powered by specifically designed power units

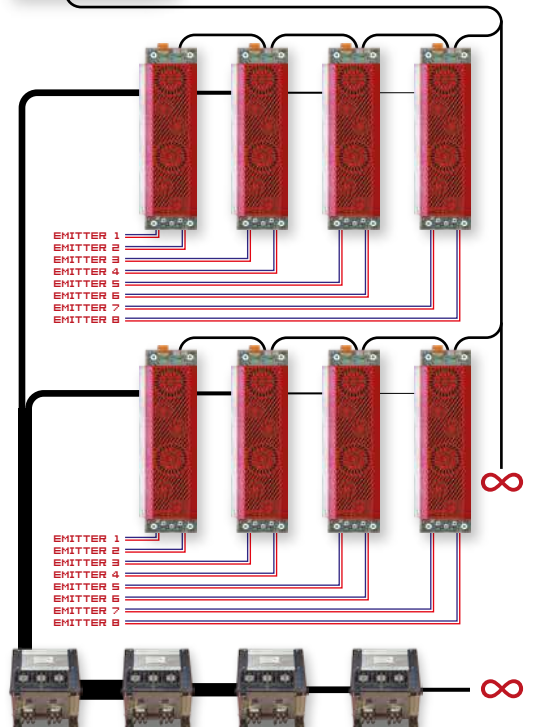

Even the electrical power system is COMPLETELY MODULAR and can be freely configured based on your specific power needs with VIRTUALLY NO LIMITS





# OPTIONALS

● Included

□ Optional

## DESCRIPTION

	ST	HL	SC	IR	
Vacuum on upper tool	1	2	2	2	1
Pneumatic valves for tool movements	2	5	5	5	2
Part detection - signals	2	5	5	5	3
Clearance between upper and lower plates	700	700	700	700	4
Opening for rear toolchange (180°)	●	●	●	●	5
safety light curtain	●	●	●	●	6
Quick Vibration stop	●	●	●	●	7
LED lighting	●	●	●	●	8
31 automatic tool detections & up to 63 tools memories	●	●	●	●	9
IR heating zones				4	10
Noise level ≤80dB	●	●	●	●	11
Quick pneumatic connection by Staubli - (8 lines RMC)	□	□	□	□	12
Quick pneumatic connection by Staubli - (12 lines RMC)	□	□	□	□	13
Additional pneumatic valve-up to 5	□	●	●	●	14
2° valve pack (+ N.5 valves/ + N.3 for IR machines) - Festo	□	□	□	□	15
Second vacuum circuit - VADMI 140 Festo (upper or lower) <sup>1</sup>	□	●	●	●	16
Third vacuum circuit - VADMI 140 Festo (upper or lower) <sup>1</sup>	□	□	□	□	17
Vacuum pump (Brand Becker) with remote digital vacuumeter - (VX 4.10 Becker) <sup>2</sup>	□	□	□	□	18
Additional vacuum circuit with remote digital vacuumeter - Festo SDE <sup>3</sup>	□	□	□	□	19
Remote digital vacuumeter <sup>4</sup>	□	□	□	□	20
Air gun outlet	□	●	□	□	21
Air gun outlet with ionized air	□	□	□	□	22
Automatic tool coupling system ×2 for small machines (for quick lower tool changing) <sup>5</sup>	□	□	□	□	23
Low pressure valve up to 300 Kg. <sup>6</sup>	□	□			24
Extractable hydraulic unit	□	□			25
Additional hydraulic unit for tool coupling			□	□	26
Hydraulic Unit cooling system	□	□			27
Upper plate with special insert (for small machines) <sup>7</sup>	□	●	□	□	28
Ball transfer units on lifting table ×8 (for small machine)	□	●	□	●	29
Ball transfer arms for rear toolchange	□	□	□	●	30
Trolley interface for toolchange on front & rear side	□	□	□	□	31
Trolley interface for toolchange on front side + security	□	□	□	□	32
Enlarged clearance between upper and lower plates = 750mm <sup>8</sup>	□	□	□	□	33
Metal hinges	□	□	□	□	34
Horizontal servo axe for "IR mirror"				□	35
Advanced HMI (SPC, historic data saving N.xxx, USB data download)	□	□	□	□	36
EPS Enhanced Power Supply (upper tool up to 50 Kg.) <sup>9</sup>	□	●	□	□	37
Traceability system (parameters recording into machine memory) <sup>10</sup>	□	□	□	□	38
Voltage stabilizer (VARAT 400V -25% +15% / 30000 VA)	□	□			39
Voltage stabilizer (VARAT 400V -25% +15% / 40000 VA)			□	□	40
UPS power backup	□	□	□	□	41
Electrical cabinet cooling system <sup>11</sup>	□	□	●	●	42
Power transformer (440-480V)	□	□	□	□	43
Digital modem for teleservice (EWON)	□	●	●	□	44
Ethernet card/wireless module for remote connections	□	□	□	□	45
USB plug for production data downloading and parameter recording	□	●	□	□	46
BADGE reader	□	□	□	□	47
External label printer (Modello Zebra S4M)	□	□	□	□	48
Integrated mini printer (Ticket with welding parameters)	□	●	●	●	49
Robot connection setup	□	●	□	□	50
Part detection management - Additional signal up to 8° (each)	□	□	□	□	51
Acoustic alarm warning	□	●	□	□	52
Light column <sup>12</sup>	□	□	□	□	53
Light column (Balluff Smart Light)	□	□	□	□	54
Second push-buttons panel	□	□	□	□	55
External lighting high performance (sun light 5000-7000°K - 1000 LUX)	□	□	□	□	56
External lighting normal LED	□	□	□	□	57
230V Power socket on front side (each)	□	□	□	□	58
Plugged electric cabinet	□	□	□	□	59
Additional 4 IR controllers (up to 16 zones) <sup>13</sup>				□	60
Rear operative panel into left door	□	□	□	□	61
Manual Bar Code reader (cable)	□	□	□	□	62
Rear operative panel into electrical cabinet	□	□	□	□	63
Start cycle optical button	□	□	□	□	64
Special color	□	□	□	□	65
Automatic vertical door on rear side	□	□	□	□	66
Rear door with transparent window	□	□	□	□	67
Enlarged soundproof cabinet +600mm	□	□	□	●	68
Soundproof cabin with electrical cabinet and OP on left side	□	□	□	□	69

<sup>1</sup> Venturi system

<sup>2</sup> 1 vacuum circuit

<sup>3</sup> Optional with vacuum pump. Up to 3 circuits

<sup>4</sup> Optional with venturi system

<sup>5</sup> Mechanical stops + sensors + hydraulic clamping system

<sup>6</sup> Allow fine regulation when pressure is lower than 300 Kg

<sup>7</sup> Suggested for frequent toolchange operations

<sup>8</sup> Enlarged clearance between upper and lower planes = 750

<sup>9</sup> Welding surface > (400 mm<sup>2</sup> (PP) 901) - (500 mm<sup>2</sup> (PP) 911)

<sup>10</sup> According to customer requirements

<sup>11</sup> On electrical cabinet and hydraulic unit

<sup>12</sup> 4 colors

<sup>13</sup> IR line has already 4 controllers

● PRODUCTION PLANTS



**Italy CEMAS Elettra**  
info@cemaselettra.com



**Germany CEMAS Germany**  
info@cemas-germany.com



**Brasil CEMAS do Brasil**  
info@cemasdobrasil.com.br



**Mexico CEMAS México**  
mexico.sales@cemaselettra.com



**Turkey CEMAS Türk**  
turkey.sales@cemaselettra.com



**China CEMAS China**  
china.sales@cemaselettra.com

● TECHNICAL AND COMMERCIAL OFFICES



**France CEMAS France**  
france.sales@cemaselettra.com



**Portugal/Spain CEMAS Iberica**  
iberica.sales@cemaselettra.com



**Russia CEMAS Russ**  
russia.sales@cemaselettra.com



**UK CEMAS UK** powered by Xfurth Ltd  
uk.sales@cemaselettra.com



**Poland CEMAS Polska** powered by KaniTech  
polska.sales@cemaselettra.com



**Romania CEMAS Romania**  
romania.sales@cemaselettra.com

■ OFFICIAL DEALERS

**USA/Canada** **EXTOL**  
sales@extolinc.com



**CEMAS ELETTRA S.R.L.**  
Strada degli Occhini, 23  
10022 Carmagnola (TO)  
Italy

P +39 011 97 12 096  
F +39 011 97 73 922  
info@cemaselettra.com  
www.cemaselettra.com